

SPECIFICATIONS OF PRO SERIES

Laser Head	Raytools
Motor Reducer	France Motovario motor reducer
Motor	Japan YASKAWA servo motor(2Y axis 850w motor and driver ,X 850w motor ,400w Panasonic servo motor and driver
Gear Rack	Taiwan APEX gear rack
Pneumatic parts	Japan SMC/Airtac pneumatic parts
Electronic Parts	French Schneider electronic parts
Guide Rail	Taiwan HIWIN /PMI guide rail
Control System	Cypcut operation system
Smoke purify system	Yes
Water cooling Machine	Yes
Independent Control Cabinet	Yes (Install Air Conditioning)
Weight	4000 Kg
Auto pallet changer	No
Enclosure	No
Rotary Attachment	Yes (Optional)
Working Area	3000 mm x 1500 mm

LEADING-EDGE TECHNOLOGY. CUTTING-EDGE PRECISION.



CARVING OUT AN EXEMPLARY WORLD OF LASER CUTTING WITH FIBER LASER PRO SERIES.

EXCELLENCE, CUT ABOVE THE REST.

Setting the future of laser cutting in motion with the best-in-class machine curated by APSOM, LCO Series and LCC Series, Open body and Closed Body respectively with Pallet Changer.

Synonymous with dynamic design, accuracy, speed, quality, and precision, these series are equipped with modern features and latest technology sourced from Switzerland. They come with a customizable fiber laser source that put customers' needs and requirements first. Thereby, delivering extraordinary output with ease, efficiency, and effectiveness.

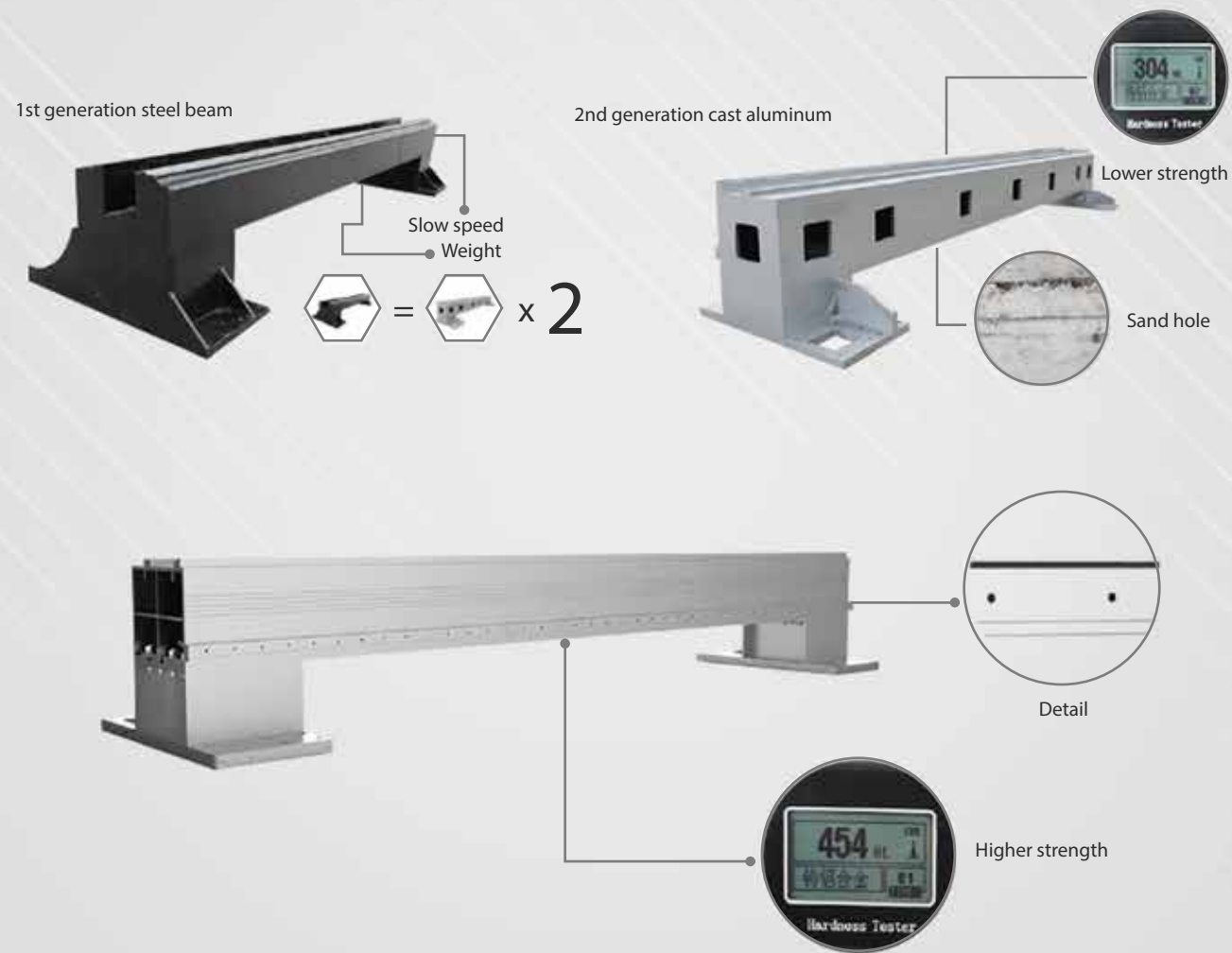

THE THIRD GENERATION AVIATION ALUMINIUM BEAM

It is manufactured with aerospace standards and formed by 4300 tons press extrusion molding. After aging treatment its strength can reach 6061 T6 which is the strongest of all beams. It got infinite advantages like toughness, light weight, corrosion resistance, anti-oxidation, low-density, and great processing speed.



LASER HEAD

Focus automatically without manual operation to realize automatic perforation and cutting plates of different thickness. Along with the speed of focus lens ten times of the manual adjusting. It also assures long service life with collimator lens and focus lens equipped with water-cooling sink heat, managing cutting head's temperature.

INDEPENDENT CONTROL CABINET

Constructed with dust-proof CE Standard Protective sign, it prolongs the lifespan of the electrical components. Combined with air-conditioner or automatic thermostat for automatic constant temperature, preventing excessive damage to components during summers.



STAINLESS STEEL PROTECTION DESIGN

THE OPERATING AREA ADOPTS A 304 STAINLESS STEEL DESIGN TO PREVENT HIGH TEMPERATURE CUTTING SPARKS FROM THE DAMAGING THE MACHINE'S SURFACE.



IPAD DESIGNING SCREEN

Experience good response speed, higher contrast, low power consumption, and high resolution with uniquely designed Ipad Screen. A vertical screen with modern display that possesses high brightness levels, lower reflectivity, and durability.

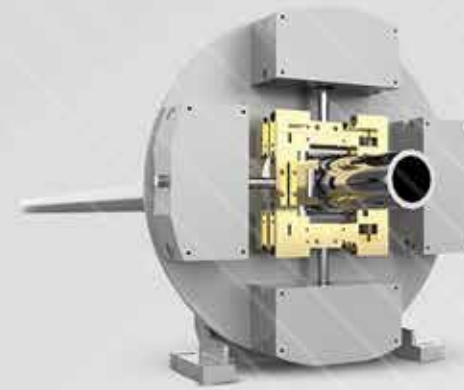

CLAMP DESIGN

It adopts an electric clamp design on both sides and it can modulate the center automatically. The diagonal adjustable range is 20-200mm.



INDUSTRY APPLICATIONS



TRANSMISSION & PRECISION

Equipped with Yaskawa Motor (Japan), Motovario Reducer (France), and Apex Rack (Taiwan). The positioning accuracy of the machine tool can be 0.02mm.



DUAL USE AND COST-SAVING

Fiber laser cutting machine can not only cut metal plates, but also metal pipes. It has many uses and can save the space of more than 50%, which effectively improve productivity.